

Technical support: Email: [tsupport@opussolutions.com](mailto:tsupport@opussolutions.com) Tel: 949-305-4200

**Package Contents**

- 1 – DCA5.80.512 or 12 Automotive intelligent DC-DC 80W Power Supply
- 1 – 8 pin power output cable with 2 HDD power (supplied with .512) or 4pin ATX12V conn
- 1 - 2 pin power switch cable.
- 1 - 6 pin DC input main power and IGN pigtail cable.
- 1 - Quick User guide (the one you are reading)

**General Information**

DCX5.080 is designed to power LOW power consumption single board computers, Peripherals such as LCD monitors, External Disk drives, Optical drives etc. It has the ability to hand shake with SBC's that are equipped with ACPI Handshake signals. DCA5s are compatible with 12 or 24 Volt battery system. The power supply ON and OFF sequence is determined by the state of ignition / ON/OFF input.

**Operating Modes**

- Mode 1: System ON/OFF controlled by ON/OFF input pin (J1 – pin 3).  
**ATX mode**, with ON/OFF input connected to Ignition switch ACC point or to an ON/OFF switch to battery.
- Mode 2: System ON/OFF controlled by ON/OFF input pin (J1 – pin 3).  
**AT mode**, (Short pins 2 and 3 of J6 with a shorting jumper). In this mode Systems handshaking are disabled.
- Mode 3: System ON/OFF controlled by Front panel soft ON/OFF push button switch.  
**ATX mode**, with ON/OFF input connected to battery along with +Batt leads (J1 – pins 4, 5) and J7, the 2 pin power switch cable is not used.

Note: Modes are determined with-in 3 sec of initial power connection to the DC-DC.

**General wiring guidelines**

Use a dedicated #12 AWG or thicker wire to connect the unit to the battery.  
Use #18 AWG wire for on/off input.  
Note: Do not share power cable with other equipment.

**Testing the DC-DC Power supply installation for proper operation in an ACPI implementation**

Power-up the computer by Turning the Ignition switch on (starting the vehicle) or toggling the switch on. The Green Status LED should light up constantly and the computer should power up normally.

(Note: After connecting the power connector to the power supply, wait for DC-DC to blink twice before turning on the IGN/ ON-OFF switch input. This procedure is required only the very first time the power is applied to the DC-DC.)

1. Open any application and test for normal operation then close the application.
2. Turn off the computer by turning the ignition switch off. Within 5-10 Sec. the PC should start to go into Standby or shut down mode and the Green status light should go back to the idle/standby blink rate.
4. Wait about 10 seconds and Turn on the Ignition switch again. The computer should power up normally.
5. Open an application for Standby mode testing. Use the application as you would normally.
6. Turn off the computer by turning the ignition switch off. The computer should go into Standby, Hibernate or Shut down mode, as configured in the operating system.
7. Repeat steps 4 to 6 for all applications that are used in your computer.

Note: All applications software must be checked for proper Standby mode operation. If any application has problem going into Standby mode then the operating system must be configured for Shutdown

**DC-DC power supply Connectors**

**J1 - Input Power, On/Off and Remote connector**

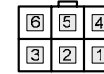

Connector type used: Molex; 39-30-1060  
Mating connector type: Molex: 39-01-2060

Pin#	Function	Description	Pin#	Function	Description
1	GND	Power Ground (Input - BLK)	4	+BATT	Battery (Input - YEL)
2	GND	Power Ground (Input - BLK)	5	+BATT	Battery (Input - YEL)
3	ON/OFF	On/Off or ACC (Input - RED)	6	RMT	Remote On/Off (Output - BLU)

RMT - (optional feature) This output can be used to turn ON/OFF the remote devices such as Audio amplifier, External DVD, Camera, etc. Remote turn ON delay is set to 20 SEC. Contact sales for other custom turn ON delay

**J11 – External / Remote LED connector**

Pin#	Function	Description
1	LED+	To External LED Anode - output
2	LED-	To LED Cathode - output
3	OB LED-	On Board LED Cathode - input



Connector type used: JST: B/S 3B-PH-K-S  
Mating connector type: JST: PHR-3

Factory Default Setting: Pin 2 and Pin 3 are shorted with shorting jumper for on board LED

To connect External LED: Remove shorting jumper and Connect Anode of external LED to pin 1 and cathode to pin 2

**JU1 – Sht-Dwn Dly, Stnd-by Power mode and Sht-dwn / Strt-up voltage Jumpers**

Psn #	Function	Description
1	SD-0	Shut Down Delay - 0
2	SD-1	Shut Down Delay - 1
3	STBY-ON	Stand-by Power ON
4	SV-0	Start-Up & Shut-Down Voltage - 0
5	SV-1	Start-Up & Shut Down Voltage - 1

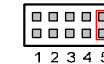

2mm Shorting Jumper installed

Start-UP & Shut-Down Voltage Select  
Stand-by Power ON/OFF  
Shut-Down Delay Time select

**Shut Down Delay Jumpers**

Psn #	- Dely	Time
1	2	

- 0 0 - (10 Sec)
- 1 0 - 10 Min
- 0 1 - 30 Min
- 1 1 - 60 Min

0 = Jumper not Installed  
1 = Jumper Installed

**Stand-by Power ON/OFF Jumper**

Psn #	3
1	2

When STBY-ON Jumper is installed, Stand-by voltage is maintained after Power down. Required for Stand-by mode operation only

**Start-UP & Shut-Down Voltage Jumpers**

Psn #	- Start-UP	Shut-Down	Voltage	Voltage
4	5			

- 0 0 - 10.5V - 8.5V
- 1 0 - 11.0V - 9.5V
- 0 1 - (11.5V) - (10.5V)
- 1 1 - 12.0V - 11.0V

(Default Factory Loading)

**J7 – Power-Switch connector**

Pin#	Function	Description
1	PWR-SW-	Power-Switch - (Output - WHT)
2	PWR-SW+	Power-Switch + (Output - GRN)



Connector type used: JST: B/S 2B-PH-K-S  
Mating connector type: JST: PHR-2

Connect to Motherboard or SBC power switch pins. OBSERVE pin polarity for proper operation

**J6 – PS-ON\* signal and Stand-by Power connector**

Pin#	Function	Description
1	5V STBY	+5V Stand-by power (output - PUR)
2	PS-ON*	Power supply ON* (input - BLL)
3	GND	Ground - (BLK)



Connector type used: JST: B/S 3B-PH-K-S  
Mating connector type: JST: PHR-3

Factory default is ATX mode operation. For AT mode operation: Short Pin 2 to pin 3 with a 2mm shorting jumper.

**J8 – Output Power connector**

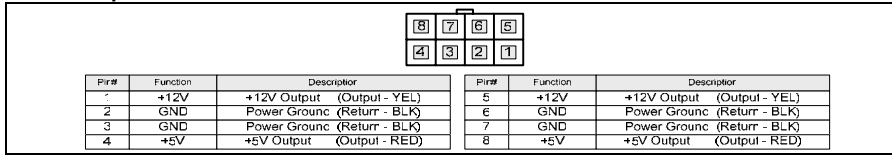

**Recommended Installation Steps**

- Step 1. Configure DC-DC JU1 jumpers. STBY-ON and Start-up and shut down voltages. Install OPUS DC-DC in the system.
  - Step 2. Configure ATX/ ITX motherboard BIOS: Turn off AC power loss auto restart, ACPI: S3, Push btn: Instant off.
  - Step 3. Configure operating system: Power-down, hibernate or Stand-by mode.
  - Step 4. Test the PC for proper operation. If all passes then, configure the DC-DC shut down delay jumpers if required.
- Suggestion: Configure and test system with a standard AC- DC power supply first. Then switch over to OPUS DC-DC power supply.

**DC-DC Application Example in and ACPI environment**

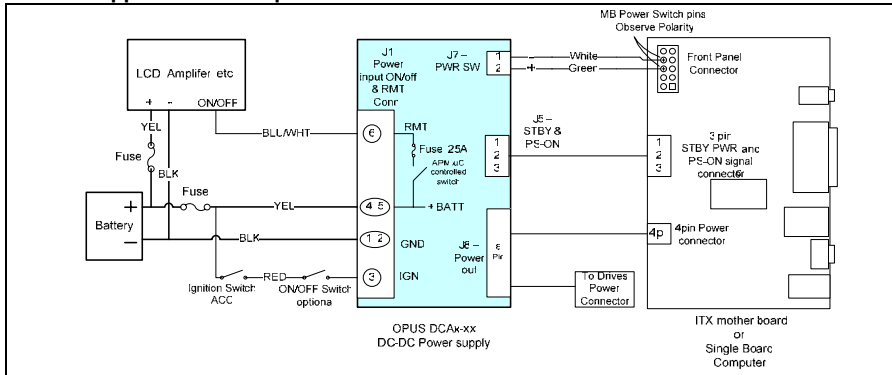

**DCX5 DC-DC PCB Dimensions**

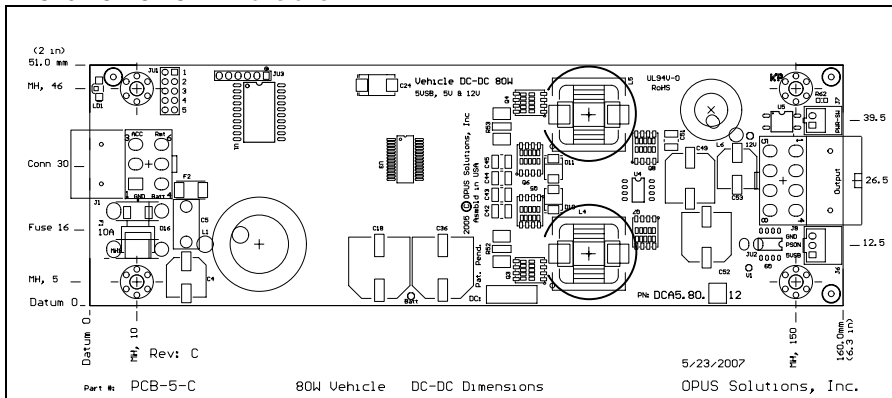

**Trouble shooting guide**

*Computer does not turn on?*

Check to make sure that battery and ON-OFF pins are connected to DC-DC Power Supply connector.

*Computer does not turn off when the ignition is turned off!*

Check the Green LED state

**Interpreting the Green Status LED light flashing**

0.1 sec ON and 5 Sec OFF Approx.: DC-DC power supply is in Idle or stand-by state.

On constantly The PC is powered and the PC should be operating.

**Error Flashes Reason**

1 Flash (every 10 Sec.) Battery voltage is below normal operating range. Voltage set by JU1 – 4, 5

2 Flashes The computer power up sequence failed. Reasons:  
 • Check the wiring of the two wire power-switch cable from power supply connector J9 to power switch pins on the ATX motherboard. If connected properly check the polarity of the power switch pins, may be reversed.  
 • Check ATX motherboard bios settings.  
 • Locked up motherboard or software crash.  
 • Faulty DC-DC power supply.

3 Flashes Power supply output voltages are out of normal voltage range. Reasons:  
 • Power supply output is over loaded or shorted.  
 • Faulty DC-DC power supply.

4 Flashes Power down, stand-by or hibernate sequence failed. Reasons:  
 • Check the wiring of the two wire power-switch cable from power supply connector J9 to power switch pins on the ATX motherboard. If connected properly check the polarity of the power switch pins, may be reversed.  
 • Check ATX motherboard bios settings.  
 • Check if ACPI function is enabled in the power management BIOS setup. Make sure ACPI drivers are installed in the operating system.  
 • Check if application is compatible with ACPI mode of operation.  
 • Locked up motherboard or software crash  
 • Faulty DC-DC power supply